

A LA VIE LA MORT

TEHNICALS DATA REQUIREMENTS

Màj.15sep2012

STAGE :

Required minimum space :

- Opening : 6 m.
- Depth : 4 m.
- Height Under ceiling : 3,50 m.

Needs :

- 4 black, adjustable writing desks of orchestra in height, blocking by lived with low dimensions in ground. Trays = 50 x 32,5cm. Height: 67 in 110 cms.
- 3 Podiums SAMIA with compass 2m x 1m. Regulation in height in 60 cms.
Covered with black carpet. Plan cloth skirts black to hide feet on the part frontal.
- 2 staircases for access to the SAMIA.
- 2 black chairs without armrests.
- 1 black stool (typify bar with a single foot).
- 1 adjustable piano stool.
- 4 crowbars in cyclo.

Variable-geometry play.

Scenography to be adapted according to the place and to the space.

For the not equipped structures (bookcase, media library, museum, etc.), a plan of installation and of lighting is planned according to a minimal configuration (see the plan below). Projectors will be connected directly and no specific electric connection will be asked (power for grada).

NB : possibility of spreading the image thrown in a bigger dimension than our screen which is of **3,60 x 2,80 m**. In that case, this data sheet will be adapted and the organizer will take it responsibility, or the surfaces of projection: tulle Tapestry 85 gr (on pipes).

VIDEO :

We can supply the vidéo-projector (VP) « Sanyo XP 100 » according to our means of transport.

The vidéo player is our hard drive.

Need stand with support for VP. Front vidéo projection, not suspended VP.

Minimum distance VP/sceen (tapestry) = 15 m.

A LA VIE LA MORT

DATA SHEET LIGHTS

Màj.15sep2012

GRADA :

14 x 2 KW (Digital technology - DMX 512)

PROJECTORS :

6 x Profile spot 1KW type Juliat 614 SX

2 x Profile spot 2KW type Juliat 714 SX

4 x PAR 64 (CP61)

STAFF :

Plan a service of 4 hours for the assembly with:

1 electro.

1 manager knowing the operating system.

CONTACTS :

LIGHTS + STAGE

Christophe SCHAEFFER : +33 6 87 50 28 23

schaeffer.c@free.fr

SOUND + VIDEO

Thierry COUSIN : +33 6 09 16 92 43

cousin.thierry@free.fr

OFFICE

ARFI : +33 4 72 98 22 00

arfi@arfi.org

A LA VIE LA MORT

DATA SHEET SOUND

Màj.15sep2012

SOUND SYSTEM

Power and diffusion according to the hall.

STAGE MONITORS

4 monitors Plugged from 4 pre-fader auxiliary front mixing desk.

Nota : No big monitors (small place). Need quality, no power.

2 speaker stands for « Vielle » and « Doublebass » monitors.

MIXING CONTROL

1 Mixing desk : if analog ; equipped complete EQ, low cut, 48 v, with **5** aux pre-fader + **2** post-fader minimum.

3 Equalizers 2 x 30 bands for front house system and monitors.

2 Reverbs Lexicon PCM 90.

ASSIGNMENT AND MIKES

1	Vielle « sympathiques »	DI	13		
2	Vielle « chien »	DI	14		
3	Vielle « bourdon »	DI	15		
4	Vielle « mélodie »	DI	16		
5	Vielle mike	Béta 57	17		
6	Vielle effects L	DI	18		
7	Vielle effects R	DI	19		
8	Doublebass 1 line mon.	DI	20		
9	Doublebass 2 line PA	Y	21	Lexicon 90 - 1 L	Line
10	Doublebass mike	Béta 57	22	Lexicon 90 - 1 R	Line
11	Sax	C414	23	Lexicon 90 - 2 L	Line
12	Trompette	C414	24	Lexicon 90 - 2 R	Line

DIVERS

4 Small stands mike (inputs 5, 10, 11 and 12).

The **5th aux pre-fader** from mixing desk will be plugged on stage, for the Vielle effects = Lexicon >> jack input connector.

NOTA

We provide the mikes C414.

Sound contact : Thierry Cousin
cousin.thierry@free.fr

BLACK CURTAIN

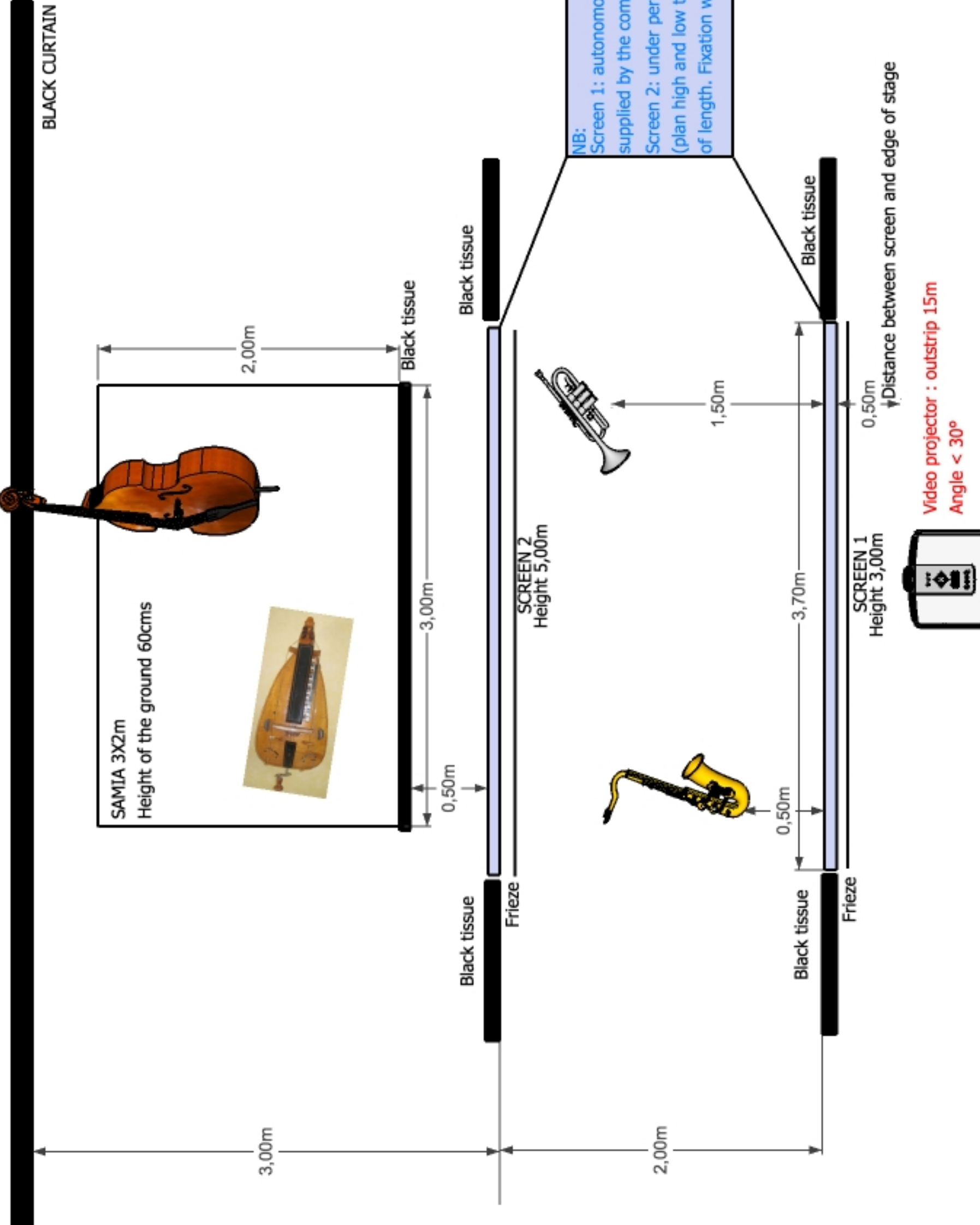

NB:
Screen 1: autonomous structure supplied by the compagny
Screen 2: under perchage on pipe (plan high and low tube of 4m of length. Fixation with white tape)

Video projector : outstrip 15m
Angle <math>< 30^\circ</math>

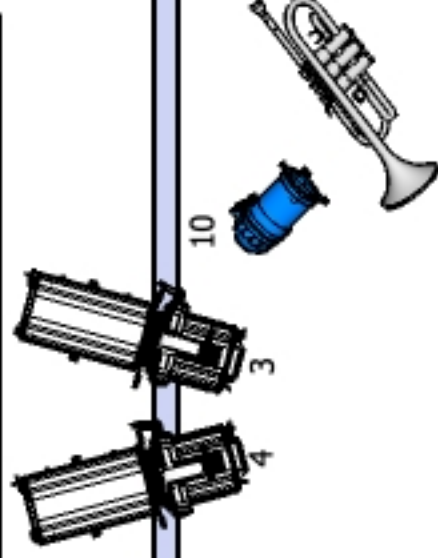
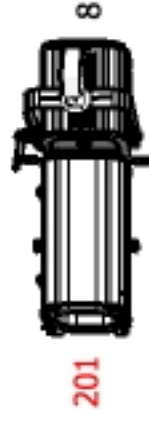
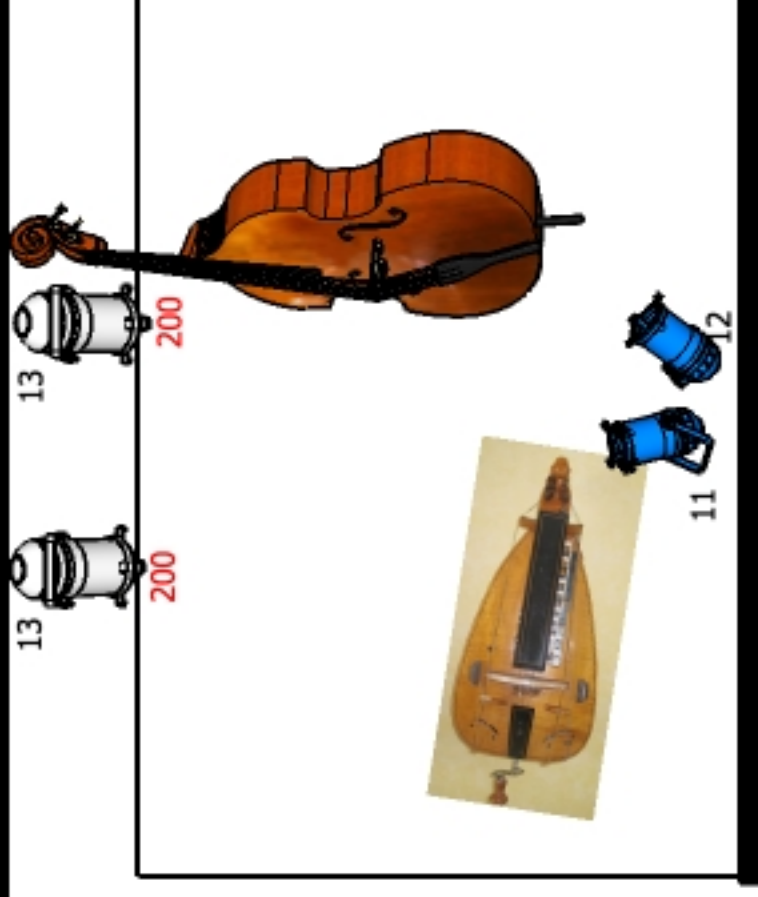

F1 PAR36 au sol (cie)
2XDECOUPE 2Kw
6XDECOUPE 1Kw
4XPAR 64 (CP61)



Porteuse face salle

PLAN DE FEUX